

HIGH-SPEED, HIGH-RESOLUTION LASER IMAGING OF MULTIHOLE FUEL SPRAYS IN A FIRING SPRAY-GUIDED DIRECT-INJECTION GASOLINE ENGINE

Isabell Düwel¹, Michael C. Drake², Todd D. Fansler²

1 Physikalisch-Chemisches Institut, Universität Heidelberg, INF 253 69120 Heidelberg, Germany
isabell.duewel@pci.uni-heidelberg.de

2 Powertrain Systems Research Laboratory, General Motors Research & Development Center, 30500 Mound Road, Warren Michigan 48090-9055, USA
michael.c.drake@gm.com todd.d.fansler@gm.com

ABSTRACT

Fuel spray imaging experiments in an optically accessible single-cylinder spray-guided direct-injection engine were performed using a long-distance microscope for high spatial resolution (~0.1 mm) and a high repetition copper-vapor laser sheet synchronized with a high-speed (9,000 and 13,500 frames/s) digital camera for high temporal resolution. Analysis of spray images near the injector nozzle exit for 100 fired engine cycles provided ensemble-averaged images and cycle-to-cycle variations. Histograms of spray angle, variations in the integrated liquid distribution (characterized by Mie-scattering intensity) along a single spray plume, and variations in local Mie intensity in a spray plume were quantified. Large droplets were observed after the nominal end of injection. These in-situ spray images are useful in choosing the optimum injector for spray guided engines.

INTRODUCTION

Spray-guided direct-injection gasoline engines have the potential for substantial improvements in fuel economy and reduced hydrocarbon emissions compared to the present generation of wall-guided direct injection engines [1,2]. However, the spark plug location is highly constrained due to the close proximity of the fuel injector and spark plug electrodes and the steep gradients in fuel concentration and velocity in the spark plug region during ignition. Even for optimized spark location and injection and ignition timing, spray-guided engines can suffer from occasional misfires and partial burns [3] [4]. The reasons for these misfires and partial burns are not well established, although others have claimed can be correlated to cyclic variability in spray cone angle[5]. The causes of misfire may vary - depending upon engine design, fuel injector type, operating conditions, and other parameters.

In the present work, we have used high speed (9,000 frames/s) Mie scattering spray images from a multihole fuel spray into a firing stratified –charge spray-guided single-cylinder research engine operating at medium speed and load. The copper vapor laser sheet lighting and high speed imaging system allowed many images in one engine cycle to identify cyclic variability in spray character which could be correlated to simultaneously-acquired cylinder pressure data. A long-distance microscope and digital camera system allowed high resolution images in regions close to the injector exit. Quantifying cycle variability in several spray parameters improves the understanding of spray fluctuations inside the spray-guided direct-injection engine and aids in the choice and optimization of the fuel injector. All experiments were performed at General Motors Research & Development, Warren Michigan.

EXPERIMENT

Figure 1 shows a schematic of the experimental setup. A single-cylinder test engine provided optical access through a quartz-window in the bottom of the piston and through two windows in the sidewalls of the cylinder head. The engine (86 mm bore and stroke, compression ratio 9.65) was fired continuously under highly stratified operating conditions (undiluted air-fuel ratio approximately 50:1) at 2000 RPM engine speed. To simulate warmed-up engine operation, the engine oil, water and intake air were preheated to 95 °C. To simulate the effects of exhaust gas recirculation on ignition and combustion, the intake charge was diluted with up to 40% nitrogen. Fuel (indolene) was injected from a centrally-located injector with 11 MPa injection pressure. For all experiments reported here, an injector with eight holes in circular configuration with a spray angle of 60° was used. The injector was oriented such that one spray plume was directed toward the center electrode of the spark plug.

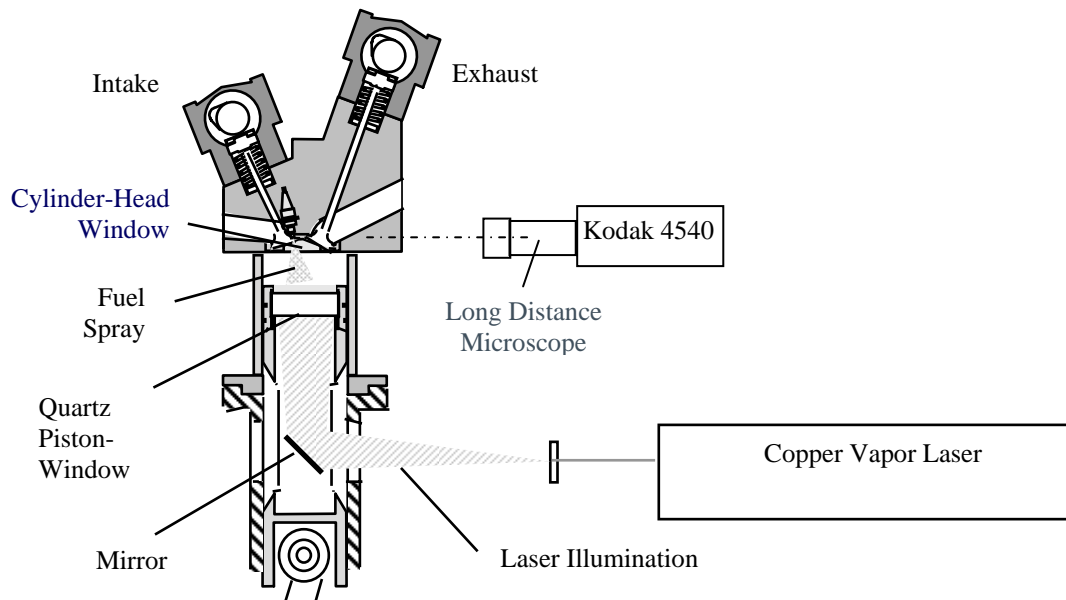

Figure 1: Experimental setup. Schematic of optical engine and high-speed high-resolution imaging system

The spray was illuminated by a copper vapor laser (30ns pulse duration, 1.2mJ total pulse energy, wavelengths of 510.6 nm and 578 nm, 9,000 and 13,500 Hz repetition rates). The laser beam was formed into a thin sheet and directed into the combustion chamber through a flat quartz window in the bottom of the contoured piston. In order to get the lightsheet to the injector tip at the top of the combustion chamber, the lightsheet was positioned to pass between the pointed electrodes of a modified spark plug.

Mie scattering by the liquid droplets in the spray plumes was detected through the cylinder-head windows by a high-speed camera system (Kodak 4540). In order to obtain high spatial resolution a long-distance microscope (Infinity K2) was used to image a small area (typically 9 mm long) near the injector tip or the spark gap.

The measured Mie scattering intensity is proportional to the cumulative droplet surface area[6]. For the ideal case of a spray with uniform and constant drop size, the Mie intensity is a quantifiable measure of liquid fuel present. For a real spray where the drop size distribution is fairly broad and where processes of breakup, evaporation, and coalescence change the local dropsizes, the Mie intensity is used as a qualitative measure of amount of liquid fuel.

RESULTS

Figure 2 shows examples of individual-cycle Mie-scattering images (left column), ensemble-averaged images from 100 engine cycles (middle column), and deviation from the ensemble-averaged images (right column) calculated by subtracting the ensemble-averaged image from the corresponding individual-cycle image. Four different times (labeled by the corresponding engine crank angle) are shown from near the start of the injection (top row), to the fully-opened quasi-steady-state part of the spray (second and third rows), to near the end of the injection (bottom row). The laser sheet intersects the two outer spray plumes, but scattered light from these dense spray plumes causes a little of the other spray plumes to also be illuminated. The spray plume on the right of each image is the plume that is directed to the spark plug center electrode, located out of the imaged field of view further away from the injector tip. The overall injection duration is approximately 0.9 ms.

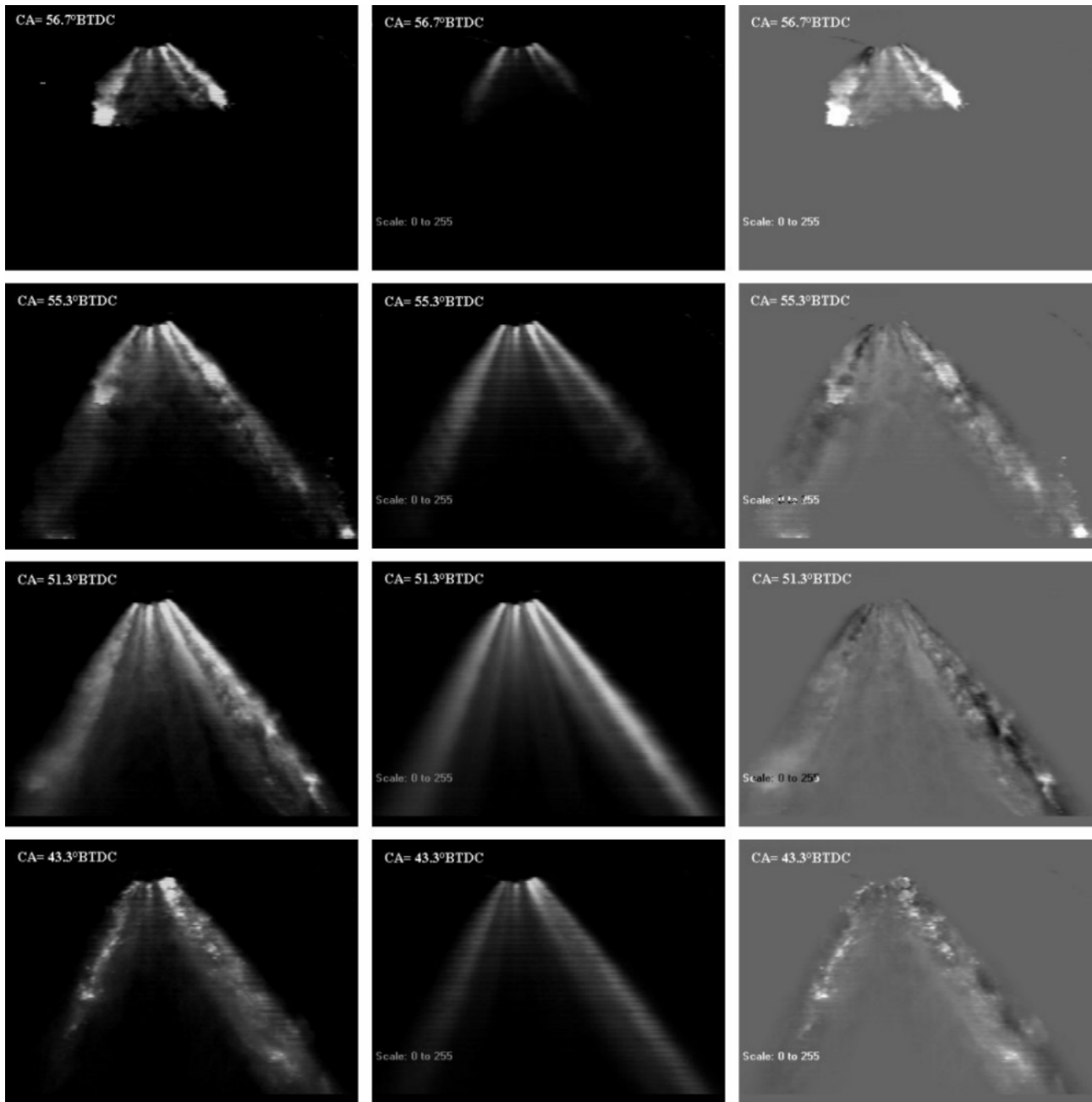

Figure 2 left column: exemplary single shot images of the spray, middle column: average Mie intensity over 100 cycles, right column: difference between single shot and average image

Analysis of the Mie images is used to quantify cycle-to-cycle variability of important spray parameters: spray cone angle (Figure 3), integrated Mie intensity along the rightmost spray plume (Figure 4), and fluctuations in a localized region of the spray plume (Figure 5).

The histogram of measured spray cone angles in Figure 3 demonstrates that the average measured cone angle of 62° is close to the nominal cone angle of 60° specified by the manufacturer, but individual-cycle cone angles vary from 57° to 72° . Others [5] have suggested that cone angle variations can be the dominant factor in misfires in their spray-guided direct injection engine. Cycle-to-cycle variation in the integrated Mie intensity in the spray plume directed to the spark gap is analyzed in Figure 4. The area averaged is shown by the white “rectangle” superimposed upon the ensemble-averaged image during the steady-state part of the spray in Figure 4a. The histogram (Figure 4b) shows there is relatively little cycle-to-cycle variability in the integrated Mie intensity. Finally, the mean and standard deviation in the integrated Mie intensity are shown as a function of engine crank angle in Figure 4c.

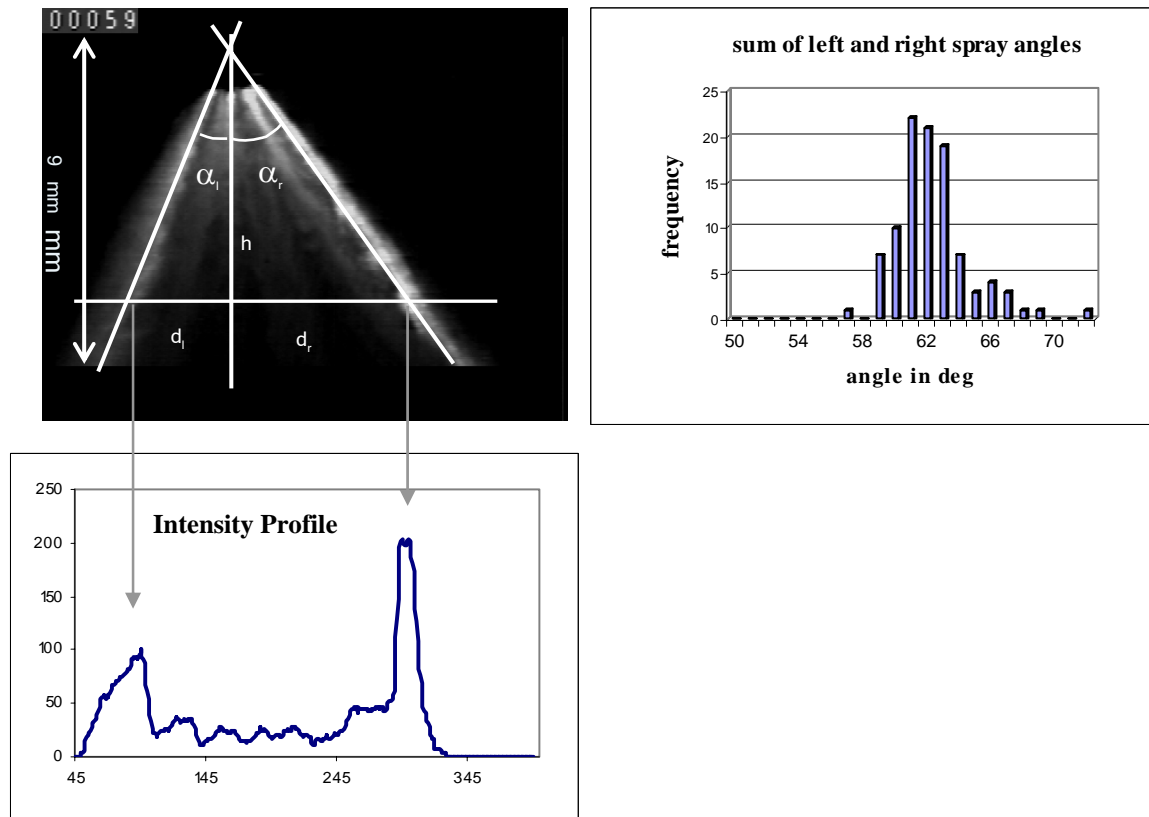

Figure 3: Single-cycle Mie-scattering image at CA= 51.3°BTDC near the tip of an eight-hole injector (nominal 60° angle between plumes) and measured variation in spray angle for 100 engine cycles. The laser light sheet was incident from below. Images were recorded at 9000 frames/s. The spark plug is out of view beyond the lower right corner of the image.

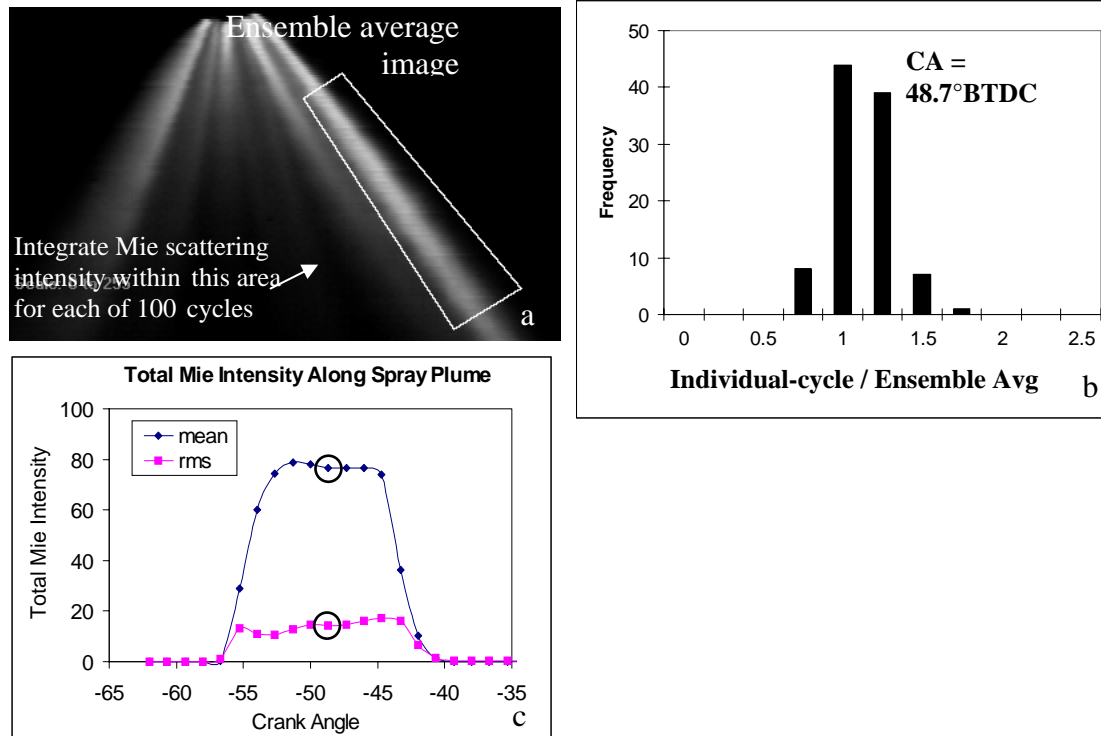

Figure 4 Fluctuations of liquid fuel along spray plume. **a:** ensemble average of Mie scattering intensity at CA= 48.7°BTDC. **b:** cycle-to-cycle variation in Mie scattering intensity. Only the outer right spray plume was considered, because this plume hits directly on the spark plug and fluctuations are therefore most likely to have an effect on the ignition process. **c:** Integrated Mie-intensity and rms as a function of crank angle. The circled data points correspond to the histogram in b.

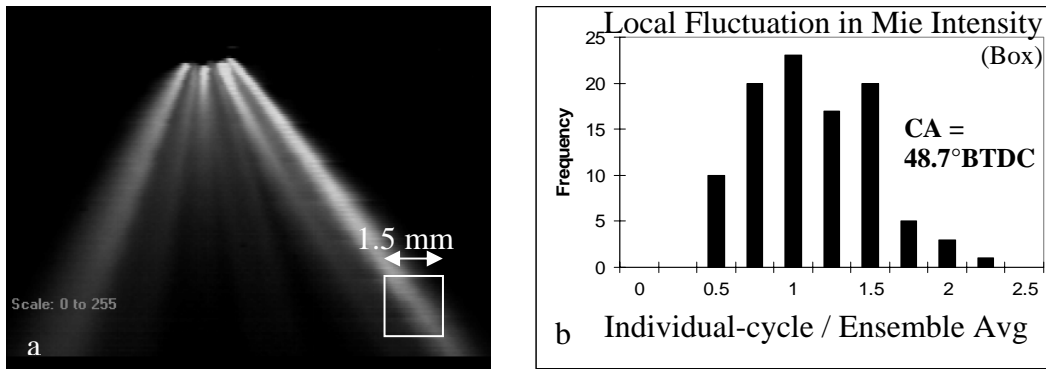

Figure 5a: Fluctuations in Mie intensity in a localized region of the spray close to the spark plug (box). **b:** histogram over 100 engine cycles.

As evident in the single-cycle images of Figure 2, there is considerable variability in Mie intensity along the spray plume direction. This variability is quantified in Figure 5 by integrating the Mie intensity over a small 1.5 mm x 1.5 mm region, as indicated by the box in Figure 5a. This size was chosen because it corresponds to a typical spark gap width. The histogram in Figure 5b, which is significantly wider than Fig. 4b, is dominated by the “clumpiness” of the Mie intensity in any given cycle, which could be due to temporal variations in the amount of fuel injected, local variations in vaporization, and local movements of the spray outside the laser sheet.

Finally, another spray parameter that showed significant cycle-to-cycle variability is the relative large droplets that form as the injector is closing (commanded end-of-injection occurs at 48 BTDC) and that travel into the chamber long after the injector should have closed. This is demonstrated in Figure 6 which shows three images from one engine cycle at late crank angles where the injector is expected to be closed. Large drops from the injector exit move diagonally-roughly along the spray plume direction- at a velocity of $\sim 7 - 15$ m/s. The number of drops and direction of travel are highly variable from cycle-to-cycle. This undesirable behavior can be minimized by injector design changes.



Figure 6 Large droplets after the end of injection.

SUMMARY AND CONCLUSIONS

High-speed Mie-scattering imaging has been used in a firing experimental spray-guided spark-ignition engine with a high-pressure multihole injector to quantify the average behavior and fluctuations (in space and time) of important spray parameters: spray cone angle, integrated Mie intensity along one spray plume, local Mie intensity, and large droplets generated as the injector closes. This detailed in-cylinder spray characterization aids in the selection and optimization of injectors for spray-guided engines.

REFERENCES

1. B. A. VanDerWege, Z. Han, C. O. Iyer, R. H. Munoz, and J. Yi, Development and Analysis of a Spray-Guided DISI Combustion System Concept, *SAE Technical Paper No. 2003-01-3105*, vol., pp., 2003.
2. S. Abe, M. Sugiyama, H. Kishi, and J. Harada, Development of a new V-6 High Performance Stoichiometric Gasoline Direct Injection Engine, *25. Internationales Wiener Motorensymposium*, pp. 82-91, 2004.
3. A. M. Lippert, T. D. Fansler, M. C. Drake, and A. S. Solomon, High-speed imaging and CFD modeling of sprays and combustion in a spray-guided spark ignition engine, *6. Internationales Symposium für Verbrennungsdiagnostik*, 2004.
4. M. C. Drake, T. D. Fansler, and A. M. Lippert, Stratified-Charge Combustion: Modeling and Imaging of a Spray-Guided Direct Injection Spark-Ignition Engine, *30th International Symposium on Combustion*, 2004.
5. W. Hübner, A. Witt, B. Hoss, T. Albrecht, B. Durst, and A. Abdelfattah, Methodeneinsatz bei der Entwicklung eines weiterführenden DI-Brennverfahrens, *24. Internationales Wiener Motorensymposium*, pp. 199-218, 2003.
6. P. Le Gal, N. Farrugia, and D. A. Greenhalgh, Development of Laser Sheet Dropsizing (LSD) for Spray Characterisation., *Proc. ILASS-Europe*, pp. 469-474, 1998.